

1) Scavo a sezione obbligata
(con eventuale scavo)

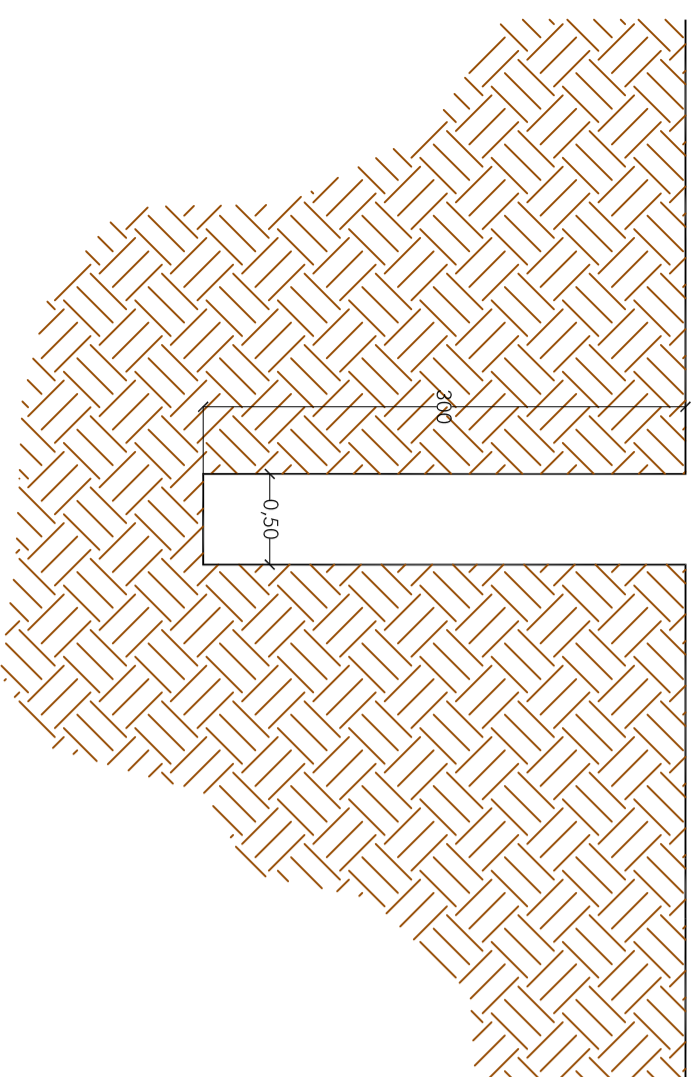

2) Posa dei pannelli DRENAR / DRENAR T

Pannello drenante DRENAR

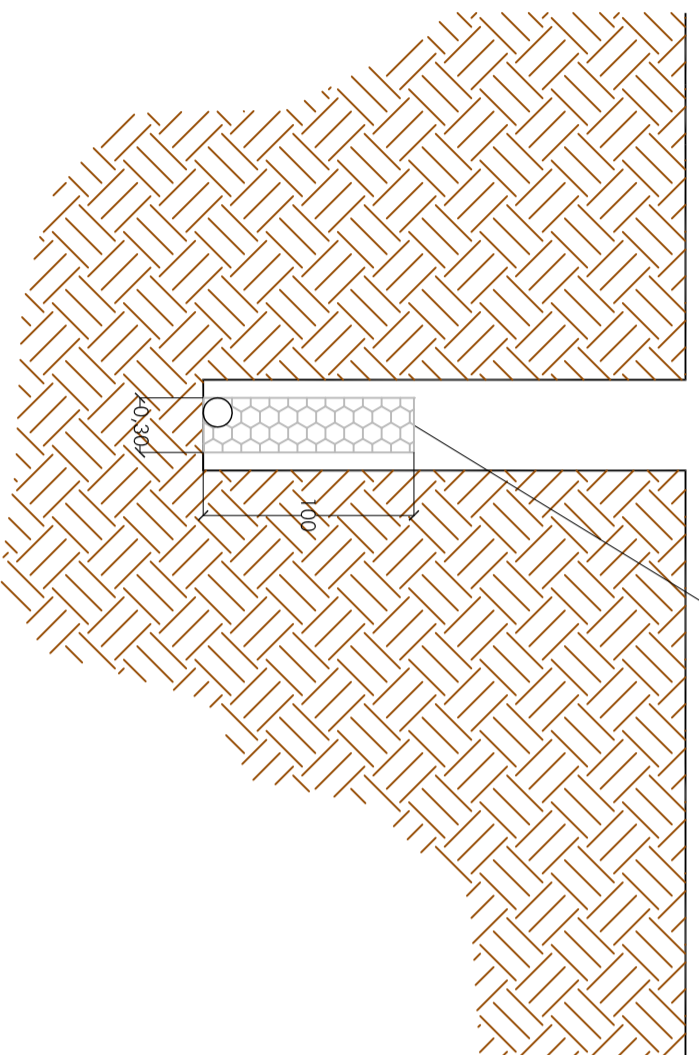

3) Rinterrò

Terreno di riporto

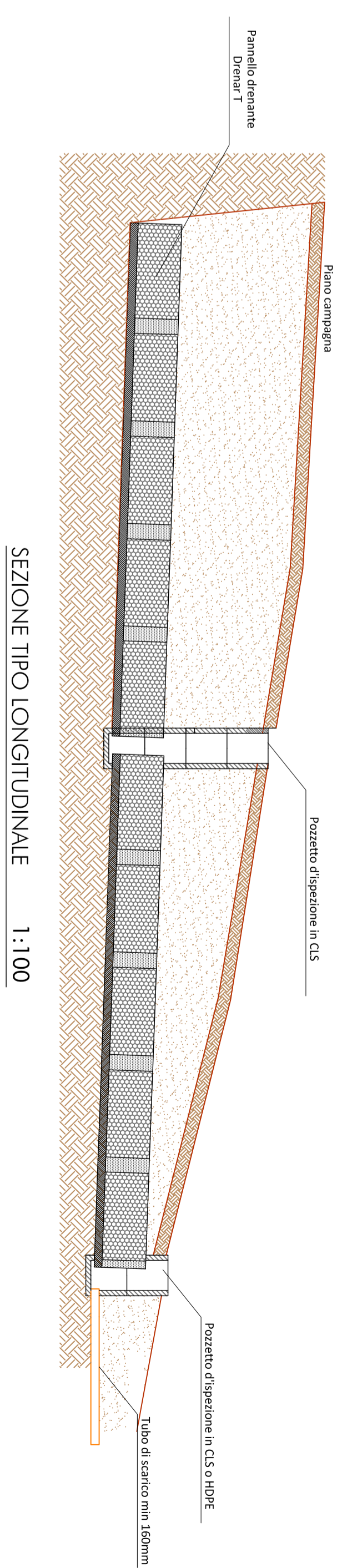
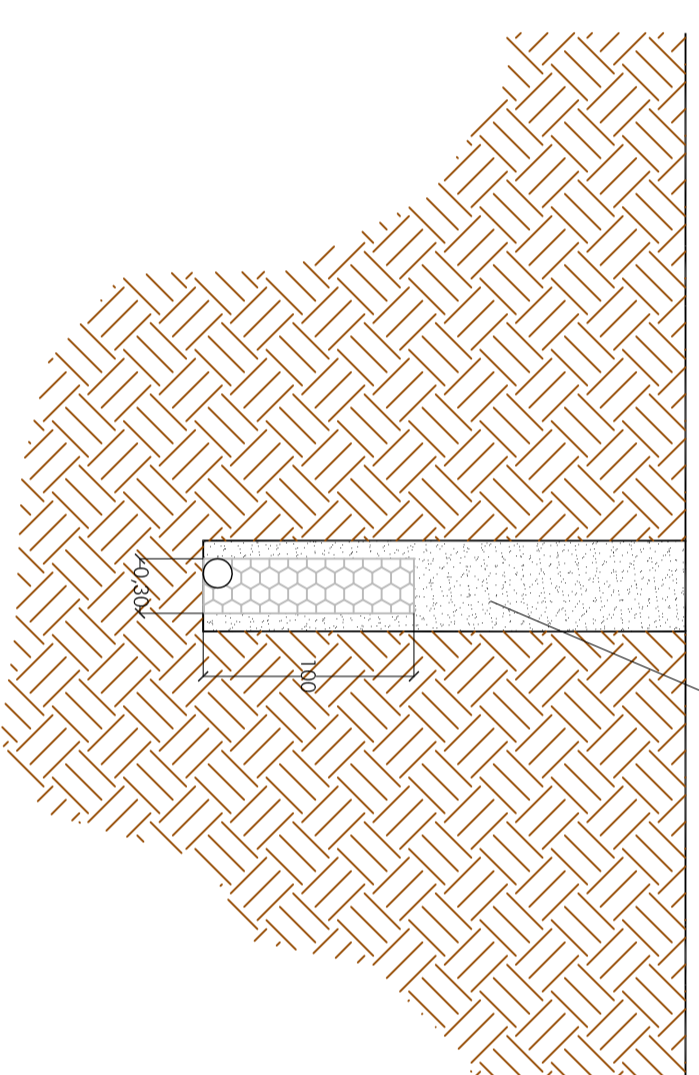

1) Posa del pannello DRENAR
(con eventuale guaina in PE alla base)

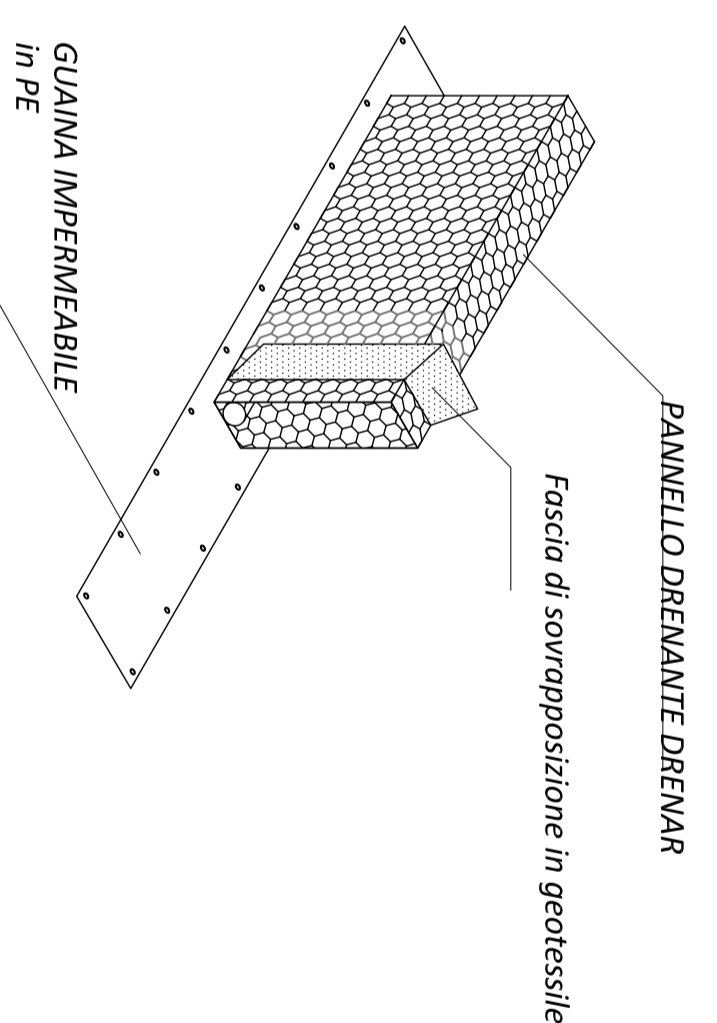

2) Giunzione dei pannelli DRENAR
con legatura a filo doppio sulla gabbia metallica

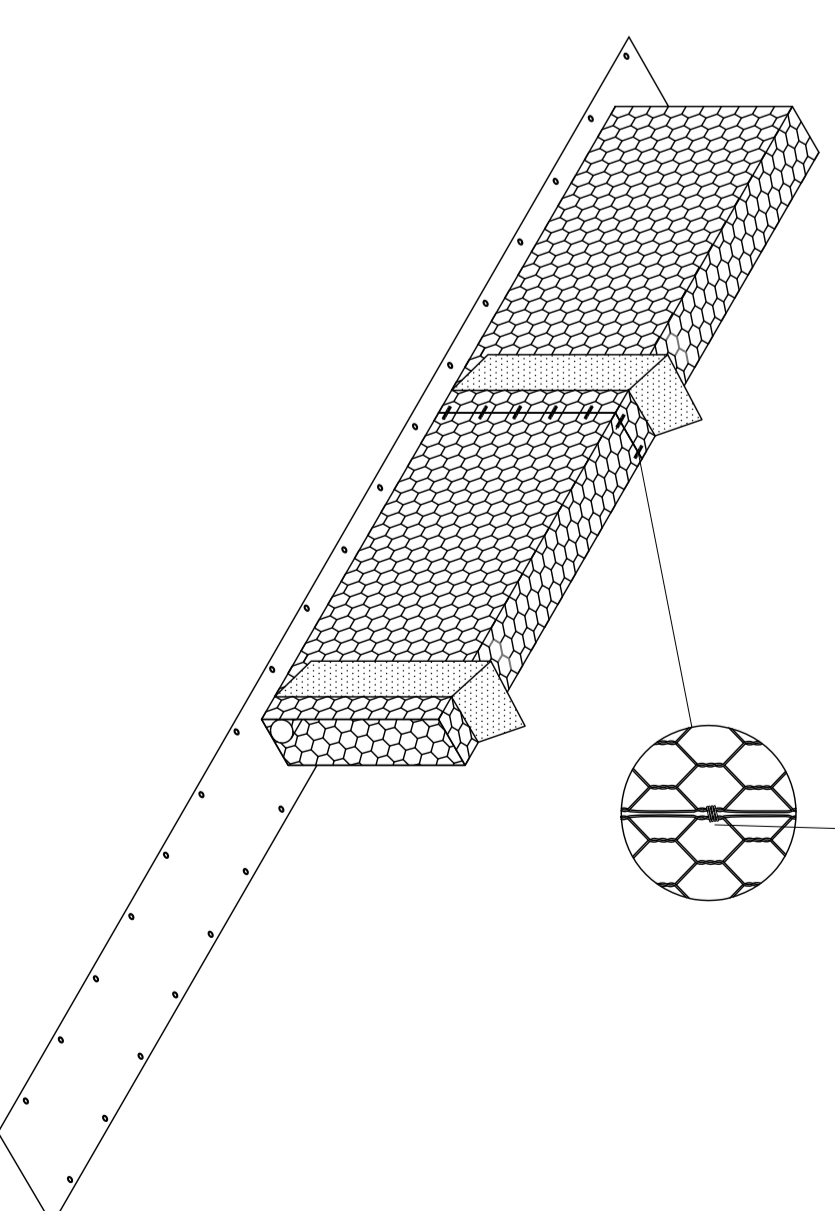

Acquedogna

SET 21

Progettato da
atc inc
studio associato
ING. Marco Tini
ING. Enrico Scavaggi

8 PLANIMETRIA
SEZIONI

P i e v e d e l c o l l e

Intervento
Messa in sicurezza
Intervento di messa in sicurezza del lotto e nucleo idrogeologico - riduzione rischio frana e aumento della sicurezza

Committente
Comune di Acquedogna
Viale Matteotti, 2
41061 Acquedogna (PR)
PR 0512220413

MODALITA' ASSEMBLAGGIO PANNELLI "DRENAR" 1:100

0722 20201 - info@pietrucciolini.com